

## Part number **TG050000** Model: **GEAR BOX ZG0302**

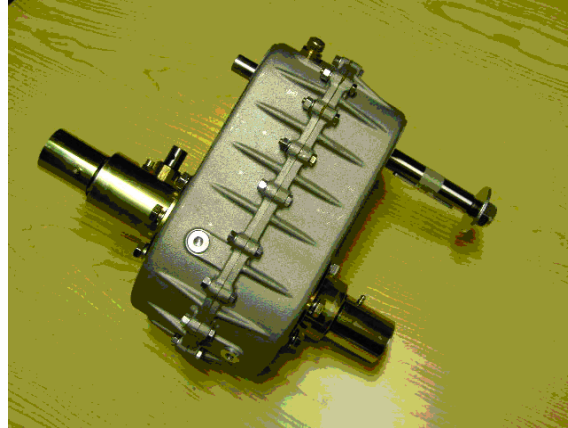
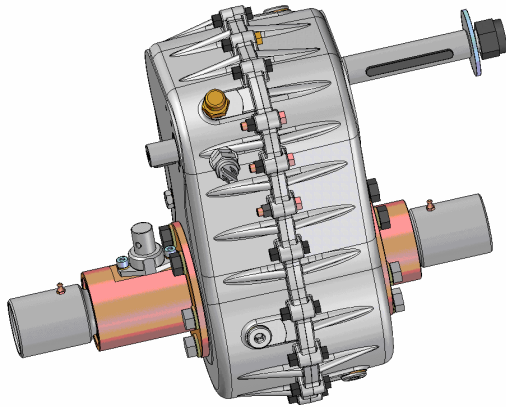

**Application fields:** Mini cars, agricultural devices, three-wheelers, golf cars, amusement vehicles, motor-sleigh, industry, etc.

**Fulfilment:** differential gear box with two forward, one reverse speeds and two neutral position; complete with central differential with block optional device.

**Drive gear ratios:**

low speed	high speed	reverse speed
7.58	4.36	4.68
9.71	5.59	6.00
11.94	6.87	7.38
15.06	8.66	9.30
17.93	10.32	11.08
4.61	2.65	2.85
7.24	3.12	-----
6.30	2.71	-----

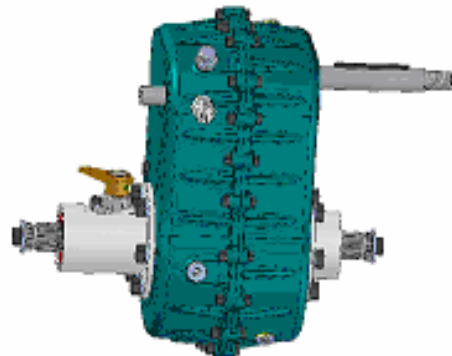

**Gears:** two forward speeds, one reverse speed and two neutral positions.

**Out-put maximum torque:** 3.000 Nm (1.500 Nm at any semi axel)

**Lubrication oil quantity:** 1,50 Kg.

**Accessories:** Intake for odometer with different ratios compare the wheel diameter, remote control with gear selector.

**STANDARD DRIVE GEARS:** 4,36:1 (L) – 7,58:1(H) or 6,87:1 (L) – 11,94:1 (H)

**THE OUT-PUT AND ENGINE SHAFTS CAN BE DRAWN IN DIFFERENT SHAPE AND DIMENSIONS AT SPECIAL CUSTOMER REQUEST.**

**WEIGHT WITHOUT ANY ACCESSORY UNITS:** 27 Kg.

**Desmodromico gear system with or without differential group, with or without block device.**